

- 10.1" Display
- 65536 True Color
- IP65 Protection, Water-Resistant and Vibration-Proof
- Bracket Mounting
- High-Speed Process with 800MHz CPU
- High Resolution up to 1280 x 800 Pixels
- Easy to Use
- Update Project Program by USB Disk

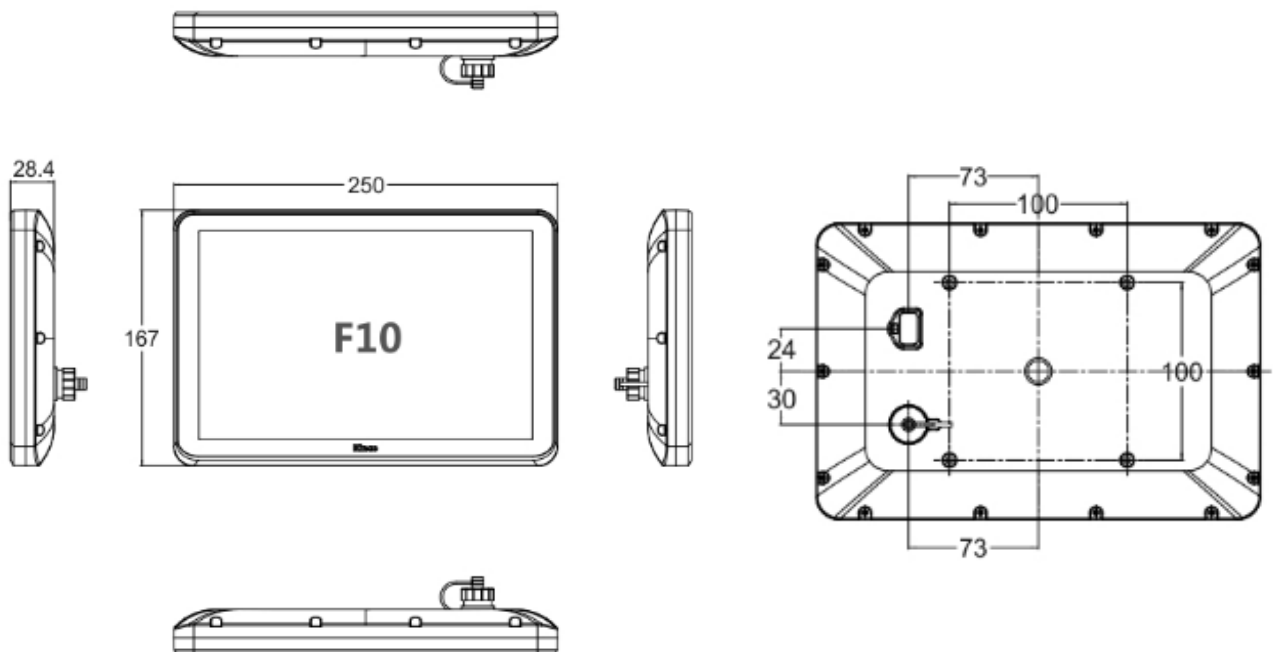

The F10 is a Water-Resistant and Vibration-Proof HMI product that will make your application run smoothly and efficiently. This F10 HMI comes with a 65536 color display mode that gives your touch screen rich color and incomparable resolution. The F10 has an IP Rating of 65 which protects it from low pressure water jets from any direction and is totally protected dust ingress. It can allow limited ingress. With the simple, convenient and powerful configuration software, the user can master its design method and create first-class programs efficiently.



Dimensions are in (mm)

L011489

Performance Specification	
Display	10.1" TFT
Resolution	1280 x 800 Pixels
Color	65536 Colors
Backlight	LED
Brightness	250 cd/m ²
Backlight Life	50000 Hrs
Touch Panel	4-Wire Precision Resistance Network
Processor	800MHz RISC
Memory	128 MB FLASH, 64 MB SDRAM
Expandable Memory	1 USB Host
Recipe Memory & RTC	512 KB & RTC
Printer Port	Serial Port
Ethernet	None
Program Download	USB Host
COM Port	COM0: PLC RS485-2W; COM2: PC/PLC RS232
Electrical Specification	
Rated Power	8 W
Rated Voltage	24 VDC (In-Built Isolated Power Supply)
Input Range	18~28 VDC
Power Down Allowed	<3 ms
Insulation Resistance	> 50M Ω @ 500 VDC
Dielectric Strength Test	500 VAC 1 Minute
Structure Specification	
Shell Color	Metal Gray
Shell Material	ABS
Dimensions(mm)	250 x 167 x 28.4mm
Cutout Size(mm)	Standard Rack Mounting
Weight	0.91 Kg
Environment Specification	
Operating Temperature	0°~45° C
Operating Humidity	10~90% RH (No-Condensing)
Storage Temperature	-10°~60° C
Storage Humidity	10~90% RH (No-Condensing)
Shockproof Test	10~25 Hz (X,Y, Z Direction, 2G, 30 Minutes)
Cooling Method	Natural Air Cooling
Certification	
Degree of Protection	IP65 (4208-93)
CE Certification	Comply with EN61000-6-2:2005 and EN61000-6-4:2007 Standards
FCC Compatibility	Complies with FCC Class A