

Kinco® N Series Stepper Motor Driver

2M1180N/2M2280N

User Manual

Version: V1.0



Kinco Electric (Shenzhen) Ltd.

Contents

Chapter 1	Safety Precautions.....	2
Chapter 2	Product Overview.....	3
2.1	Product Acceptance	3
2.2	Product Model Description	3
2.3	Product Overview	3
2.4	Product Features	4
2.5	Product Functions.....	4
2.6	Scope of Application.....	5
Chapter 3	Product Parameters and Installation	6
3.1	Product Parameters	6
3.2	Description of Wiring Terminal	6
3.3	Wiring Diagram	8
3.4	Time Sequence Diagram of Control Signal.....	9
3.5	DIP Switch Settings.....	10
3.6	Installation of the Driver	11
Chapter 4	FAQ.....	12
4.1	Indications of Driver Indicators	12
4.2	FAQ on the Driver and Stepper Motor	13

Release Notes on N Series Multi-functional Micro-step Stepper Motor Driver User Manual

Products involved: 2M2280N and 2M1180N stepper motor drivers.

Version: V1.0

Date: Apr, 2, 2009

Revision History		
Version	Date	Description
V1.0	2009-4-2	

Chapter 1 Safety Precautions

For the sake of personal safety and avoidance of property loss, please read these safety precautions carefully before test running and use of the driver.

The following safety measures must be strictly followed:

- λ Read this user manual carefully.
- λ Observe safety precautions strictly.
- λ After being powered on, the voltage in side 2M2280N driver is about 300VDC and the voltage inside 2M1180N driver is about 150VDC. The high voltage still exists after the power supply is cut off. Before performing any wiring or check operation, use a multimeter to verify that the voltage on the driver terminals is safe; otherwise, the electric shock may occur.
- λ Never connect wires while the driver and the motor are working; otherwise, the electric shock may occur.
- λ Do not remove the housing of the driver when the power is on or the driver is working; otherwise, the electric shock may occur.
- λ To avoid personal injury and property loss, only qualified and service-trained personnel can operate the driver.
- λ Follow related technical specifications and electric installation standards during installation. The driver must be securely grounded with the cross section of the ground cable not less than 1.25 mm².
- λ Do not insert any object into the driver, which may cause damage to the equipment.
- λ If any fault occurs to the driver, please return the driver to the maintenance and repair center. Opening the driver without authorization or improper operation may cause damage to the driver. Removing the enclosure of the driver without authorization will void the warranty.
- λ The waste driver shall be disposed of as industrial waste to avoid environmental pollution.

ⓘ Statement:

- λ When this driver is applied in some mechanical instruments where personal safety is directly involved (e.g. nuclear power control, medical device, truck, train, airplane, amusement and safety devices), be sure to install proper fault-proof devices to avoid the possibility of personal injury.
- λ Electronic devices are not permanently reliable! Adequate safety measures must be taken to ensure personal and equipment safety in case of a failure. The users must be liable for any loss resulting from equipment fault or misoperation of the driver.

Chapter 2 Product Overview

2.1 Product Acceptance

Upon receiving the product, please check the following items:

- λ Make sure the driver model is consistent with that ordered.
- λ Unpack the product and make sure it is free from damage and no part is missing.
- λ Make sure all set screws in the driver are securely tightened.
- λ Check the received product against the packing list and contact our customer service center in time if any part is missing.

Packing List	
Article	Qty.
2M2280N driver or 2M1180N driver	1 pcs
After-sales Service Registration Form	1 pcs
Product Service Terms and Conditions	1 pcs
User Manual	1 pcs
Certificate of Conformity	1 pcs
2k metal film DIP resistor	3 pcs

2.2 Product Model Description

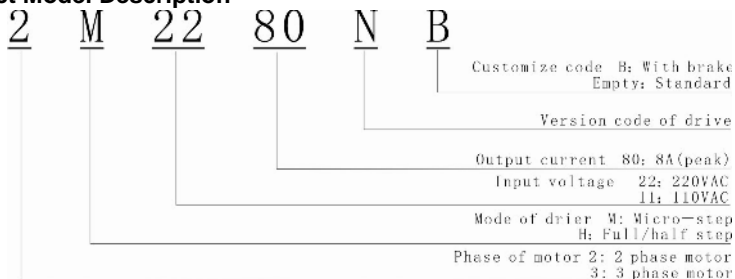

2.3 Product Overview

N series drivers are the latest high-subdivision stepper motor drivers launched by Kinco Electric (Shenzhen) Ltd. With the DSP single-chip microcomputer as the control core, these products adopt vector current control algorithm and are suitable for driving 2-phase hybrid stepper motors under various brand names. The application of advanced vector control algorithm reduces remarkably the noise and vibration of the motors during operation, and enables the stepper motors to deliver a noise and stability level comparable to that of servo motors. The brand-new radiator design enables the drivers to meet the strict safety requirements while keeping a compact structure.

2.4 Product Features

- λ High performance, low cost, and diversified functions
- λ 2M2280N adopts 187V~253V wide-range power supply and can be connected directly with single-phase 220V AC power to save the cost of a transformer
- λ Automatic parameter adjustable regulation
- λ Supporting driver test running function
- λ Supporting phase memory function
- λ Supporting PLS+DIR and CW/CCW control signal
- λ Supporting optocoupler isolation ERR signal output function and interaction with the upper computer
- λ Output current of the driver automatically reduces by a half in 1.5S after the driver gets static
- λ Opto-isolation signal input, with pulse response frequency up to 400 KHz
- λ Simple and easy subdivision and current setting
- λ 12 micro-step value, the maximum micro-step value is 128
- λ With the protection function of over-voltage, under-voltage, over-current, overheat

2.5 Product Functions

2M2280N stepper motor drivers adopt DSP single-chip microcomputer as its control core, which greatly enriches their applications. Meanwhile, the intelligent firmware design frees the users from complicated function setting steps and delivers the optimum performance of the motors easily.

- λ **Motor auto adaptation:** The driver can automatically detect the electrical parameters (e.g., inductance and resistance) of the motor connected with the driver, trace the status of motor in real time, and automatically adjust the driver parameters according to the detected motor status to deliver the optimum driving performance. If it is not the first time for the driver to drive the motor, please run the driver under no load before connecting the motor. Then, the driver will clear the motor parameters stored before. Turn off the power, connect the motor, and turn on the power again; the driver will automatically detect the optimum drive parameters for the current motor.
- λ **Phase memory:** The driver will keep the phase of the motor in the case of power failure with the motor. Therefore, it prevents the error caused by motor jitter upon power-on on some application occasions. The kept phase will be lost if the motor is replaced or the motor still rotates after the driver stops.
- λ **Automatic half current:** After the motor stops rotation and locks tight, the driver will reduce the phase current of the motor by a half in 1.5 seconds to cut down the heat generated by the motor, theoretically, by 25%.

- λ **Test running:** If the driver is set to this status, it will automatically drive the motor at a speed of 60RPM. At this time, the output current is the set value and the subdivision setting becomes invalid. This function is used to check whether the driver status is normal.
- λ **PLS+DIR and CW/CCW compatible input:** The control signal input port of the driver supports “PLS + DIR” control signal and “CW/CCW” control signal input.
- λ **Over-voltage alarm:** The driver will generate a high-voltage alarm if the internal bus voltage exceeds 395 VDC in the case of the 2M2280N driver or 187VDC in the case of the 2M1180N driver. At this time, turn off the power supply in time and reboot the driver to clear the alarm. If the over-voltage alarm occurs frequently, it is recommended that the input voltage be tuned down or a driver with absorption function be adopted.
- λ **Over-current alarm:** The driver will activate the over-current protection function in the case of short-circuit or wrong wiring of the motor or driver, so as to prevent the damage to the driver. In this case, turn off the power supply in time and check the wiring of the motor. To clear the alarm, reboot the driver.
- λ **Under-voltage alarm:** The driver will generate a low-voltage alarm if the internal bus voltage goes below 200 VDC in the case of the 2M2280N driver or 90VDC in the case of the 2M1180N driver. To clear the alarm, reboot the driver.
- λ **Overheat alarm:** The driver will generate a overheat alarm if the internal temperature reaches 75°C.
- λ **Miss-connection protection:** The driver will generate a miss-connect alarm if the wiring between the driver and the motor is wrong. To clear the alarm, reconnect the wires correctly.

2.6 Scope of Application

The drivers are applicable to various large and medium automation equipment and instruments, including engraving machines, labeling machines, cutting machines, numerical control machine tools, and plotters. They are ideal choices for users in search of low vibration, low noise, high accuracy, and high speed.

To achieve the optimum performance, KINCO 110 and 130 series stepper motors are recommended.

Chapter 3 Product Parameters and Installation

3.1 Product Parameters

Please learn carefully the driver parameters before use. Make sure the power supply and operating environment conform to relevant requirements.

Table 1 Electrical Specifications

Parameter	Description
Input voltage	2M2280N: Single-phase 220V AC +/-15% (50Hz)(187VAC~253VAC)
	2M1180N: Single-phase 77V AC~123VAC, (50Hz)
Phase current(peak)	4.5A,5A,5.5A,6A,6.5A,7A,7.5A,8A
Micro step	2/4/5/8/10/16/20/32/50/64/100/128
Input signal	Three control signal ports: PLS(CW)/DIR(CCW)/FRE; current range: 6~16 mA
Signal input method	PLS+DIR; CW/CCW
Output signal	ERR, open collector output
Automatic half current	Waiting time for automatic half current: 1.5s; phase current decreased by 50%
Protection	Over-voltage, under-voltage, over-current, and overheat protection
Absorbing circuit*	Need customize, used to absorb the energy feed back by the motor

Table 2 Operating Environment

Cooling method	Forced air cooling	
Environment	Operation environment	Avoid the environment with great amount of metallic powder, oil mist, or erosive gases.
	Operation humidity	<85%, RH (non-condensing or water drops)
	Operation temperature	0°C ~ +40°C
	Storage temperature	-20°C ~ +70°C
Weight (net)	1.5Kg	
Dimensions	201mm×147mm×66mm	
Ingress protection	IP20	

3.2 Description of Wiring Terminal

Wiring terminals of the driver are divided into three types: control signal port, motor power cable port, and power input port. Control signal port can receive differential signal, single-ended common-cathode and common-anode signals, and can prevent the interference of ambient environment on the driver with the built-in high-speed optocoupler.

The twisted pairs are recommended as signal lines for enhanced interference immunity in environments with strong electromagnetic interference. The definitions of the driver ports are detailed below:

Table 3 Definition of Control Signal Port

Signal	Functional Description
PLS+(CW+)	Pulse signal. In the PLS+DIR control signal mode, the signal is the pulse control signal and the rising edge is effective.
PLS-(CW-)	In the CW/CCW control signal mode, the signal is the forward rotation control signal and the rising edge is effective. The high-level time shall not be less than 1.25uS to ensure reliable response of the internal optocoupler. The maximum input frequency of the pulse signal is 400 KHz
DIR+(CCW+)	In the PLS+DIR control signal mode, the signal is direction control signal, and the driver sets the rotation direction of the motor by detecting the level of this signal. A direction signal shall be set up 20uS earlier than a pulse signal.
DIR-(CCW-)	In the CW/CCW control signal mode, the signal is the reverse rotation control signal and the rising edge is effective. To ensure reliable response of the internal optocoupler, the high-level time in this mode shall not be less than 1.25uS. The maximum input frequency of the pulse signal is 400 KHz
FREE+	This signal is offline signal. If the signal is at a high level, the driver turns off the power supply for the motor, and the motor rotor turns into Free status (Offline). Adequate measures must be adopted to prevent the motor from causing equipment damage or personal injury when it is in the offline status.
FREE-	
ERR+	Alarm output signal. This signal port is the optocoupler output port for open collector. When the driver has an exception alarm or power failure alarm, this signal port outputs a low-level signal. For this port, the maximum allowable input voltage is 30V DC and the maximum supply current is 10 mA.
ERR-	

Table 4 Definition of Strong Current Port

Signal	Functional Description
A+	Phase A of motor. The switching between A+ and A- can change motor rotation direction.
A-	
B+	Phase B of motor. The switching between B+ and B- can change motor rotation direction.
B-	
R+	Absorbing (Break) resistor port.
R-	

Table 5 Definition of Power Input Port

ACN+	Power input ports for the driver. The 2M2280N driver can be connected to a single-phase 220V AC source directly.
ACL-	
PE	Grounding terminal of the driver

3.3 Wiring Diagram

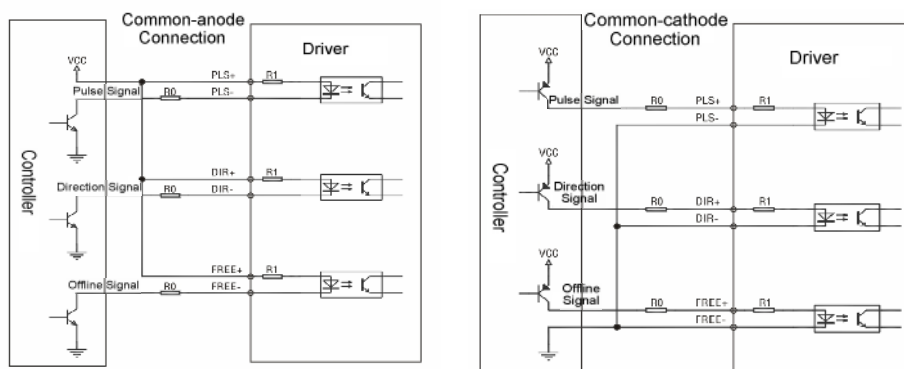
**Control Signal Wiring Diagram**

- λ The input circuits of all control signals of the driver have been reliably isolated through optocoupler elements, which minimize the interference from external electrical noises.
- λ In the figure, R0 is an external current limit resistor used to curb the input signal current of the driver. When control signal is at 24VDC, a 2K resistor can be connected; when the control signal is at 12VDC, a 1K resistor can be connected. The current at the input port of the driver must be within 6~16 mA; otherwise, it may cause damage to the equipment.
- λ ERR signal is open collector output and requires an external power supply. The maximum external voltage cannot exceed 30V. Never connect the ERR signal port in reversed polarity; otherwise, it may cause damage to the port.

3.4 Time Sequence Diagram of Control Signal

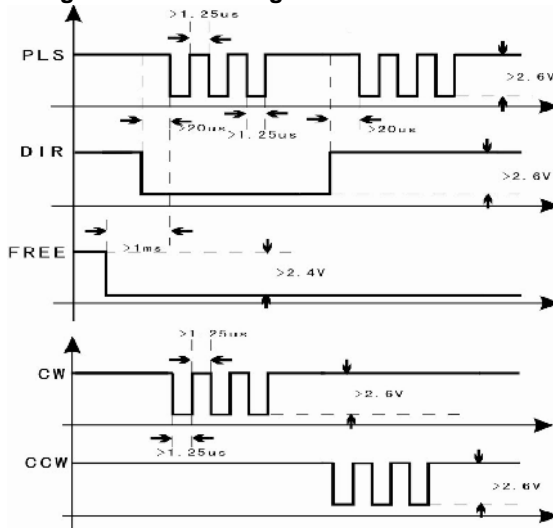

⚠️ Precautions on Control Signal:

- λ The maximum frequency of the input pulse is 400 KHz.
- λ A direction signal shall be set up 20µs earlier than a pulse signal.
- λ An offline signal shall be set up 1ms earlier than a pulse signal.

⚠️ Precautions on Wiring:

- λ To avoid interference on the driver, the strong current cables (phase wires and power cables of the driver) shall be isolated from the weak current cables (for a distance of at least 10cm) when connecting wires for the driver.
- λ It is recommended that the twisted pairs be adopted for control signal cables for the driver, and the shielding layer be grounded reliably (to the true ground of the driver and equipment).
- λ Due to endurance of heavy current, conductors with cross-section no less than 1.5mm² are recommended for the motor cabling, or even thicker ones as appropriate.
- λ It is strictly forbidden to connect wires while the power is on; otherwise, it may cause equipment damage and personal injury. Please note that the power line of the motor still carries heavy current even if the motor is in the locked status. Pull out or connect the wire forcibly may cause equipment damage and personal injury.
- λ The length of bare wires at the inputs of the power line of the motor and the power input cable of the driver shall be around 10mm; it may result in poor contact if the length is too short and may cause electric shock if the length is too long.

3.5 DIP Switch Settings

The driver is configured with two round DIP switches S1 and S2, which are used for macro-step value selection, current value selection, test running status enabling, and PLS+DIR or CW/CCW control signal selection.

- λ Test running: When S1 is set to E, the driver goes into the test running status. In the test running status, the driver will output the current as per the set value and drive the motor at a speed of 60 RPM. At this time, the RUN indicator blinks slowly, the POWER indicator is on, and other indicators go off.
- λ Switching between PLS+DIR and CW/CCW control signal modes: When S2 is set to 0~7, the driver works in the PLS+DIR control mode; when S2 is set to 8~F, the driver works in the CW/CCW control mode.

S1, Micro-step:

S1	0	1	2	3	4	5	6	7
Micro step	2	4	5	8	10	16	20	32
Pulse/rev	400	800	1000	1600	2000	3200	4000	6400
S1	8	9	A	B	C	D	E	F
Micro step	50	64	100	128	NA	NA	TEST	NA
Pulse/rev	10000	12800	20000	25600				

S2, Current:

Mode	PLS+DIR							
S2	0	1	2	3	4	5	6	7
Rms(A)	3.18	3.54	3.89	4.24	4.60	4.95	5.30	5.65
Peak(A)	4.5	5	5.5	6	6.5	7	7.5	8
Mode	CW/CCW							
S2	8	9	A	B	C	D	E	F
Rms(A)	5.65	5.30	4.95	4.60	4.24	3.89	3.54	3.18
Peak(A)	8	7.5	7	6.5	6	5.5	5	4.5

Precautions on rotary switch:

- λ S1 cannot be set to NA; otherwise, the driver will generate an alarm. In this case, turn off the power, re-set the macro-step values, and turn on the power again to resume normal.
- λ To set the status of the DIP switch, choose an appropriate straight screwdriver; a screwdriver of inappropriate size may cause damage to the DIP switch.
- λ When setting the status of the DIP switch, do not apply an axial force; otherwise, it may cause damage to the DIP switch.

3.6 Installation of the Driver

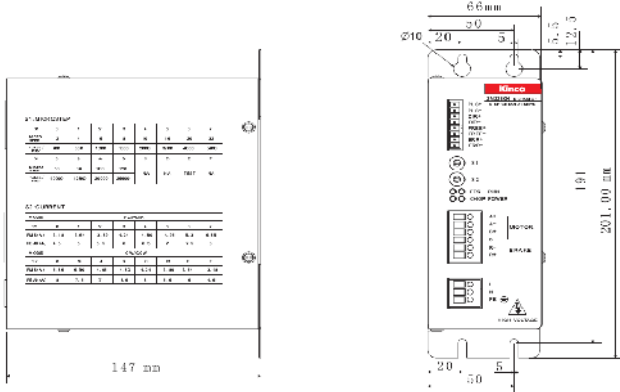

Mechanical Dimensions

Precautions on Installation:

- λ It is recommended that the driver be mounted on a side and kept in an upright position, so as to maintain a well ventilated installation environment. Never block or cover the air vents of the driver; otherwise, the normal use of the driver may be prevented by possible frequent overheat alarms.
- λ For better heat dissipation, two drivers shall be installed at a clearance of at least 50mm.
- λ With an ingress protection class of IP20, the driver shall be installed in an industry-compliant indoor switching cabinet; failure to do so may cause damage to the driver or personal injury.
- λ Enhanced heat dissipation is required if the driver generates overheat alarms frequently. A fan may be installed in a position close to the driver for forced cooling and heat dissipation, so as to ensure the driver works in an allowable temperature range.

Chapter 4 FAQ

4.1 Indications of Driver Indicators

N series stepper motor drivers are equipped with complete protection circuits to protect their safety to the greatest extent possible. In addition, the rich indications of indicators help the user to learn the working status of the driver in time.

Indications of Indicators:

Alarm	Indicator				Motor Status
	Power	Run	Error	Chop	
Internal power failure	Off	Off	Off	Off	The motor power supply disconnects and the motor shaft releases
Single-chip microcomputer resetting	On	On	On	On	The motor power supply disconnects and the motor shaft releases
Hardware error	On	Off	On	On	The motor power supply disconnects and the motor shaft releases
Motor phase-to-phase error	On	Off	On	Blink quickly	The motor power supply disconnects and the motor shaft releases
Over-current alarm	On	Off	Blink quickly	Off	The motor power supply disconnects and the motor shaft releases
Over-voltage alarm	On	Off	Blink quickly	Blink quickly	The motor power supply disconnects and the motor shaft releases
Overheat alarm	On	Off	Blink slowly	Off	The motor power supply disconnects and the motor shaft releases
Under-voltage alarm	On	Off	On	Off	The motor power supply disconnects and the motor shaft releases
DIP switch error	On	Blink slowly	On	Off	The motor power supply disconnects and the motor shaft releases
Motor cable not connected	On	Off	On	Blink slowly	The motor power supply disconnects and the motor shaft releases
Normal running	On	On	Off	Off	The motor runs normally
Test running	On	Blink slowly	Off	Off	The motor runs normally
Braking	On	On	Off	On	The motor runs normally

 Note:

- λ Blinking slowly means blinking at a frequency of 0.5 Hz, and blinking quickly means blinking at a frequency of 5Hz.
- λ To clear any alarm of the driver, it is necessary to disconnect the power supply and then reboot the driver.
- λ In the case of any alarm, it is necessary to disconnect the power supply in time, and never touch the driver and motor when the power supply of the driver is on.
- λ Except for the normal running, test running, and absorbing status, the driver ERR signal will output a low level.
- λ If any indication not covered in the above table occurs, please contact our customer service personnel.

4.2 FAQ on the Driver and Stepper Motor**1. What is the maximum allowable surface temperature for a stepper motor?**

The excessively high temperature will demagnetize the magnetic materials of a stepper motor and as a result, cause lower torque or out of step of the motor. Therefore, the maximum allowable surface temperature of a stepper motor depends on the demagnetization point of different magnetic materials. In general, the demagnetization point for magnetic materials is above 130°C, so it is normal if the surface temperature of a stepper motor remains at 80°C - 90°C.

2. How to calculate output power of a stepper motor?

The output power of a stepper motor varies with the rotation speed and is generally measured by torque. The calculation formula for output power of a stepper motor is: $P=\omega*M$; where, $\omega=2\pi*n/60$, ω indicates the angular speed and M indicates the output torque.

3. What is the subdivision function of the driver intended for?

The subdivision function of a stepper motor driver is a kind of electronic damping technology. It has three distinctive functions:

- A. It enhances the control accuracy due to the subdivision of step angles.
- B. Subdivision is the best method to suppress the low-frequency oscillation of the motor.
- C. It can enhance the motor torque to some extent.

Kinco

To be the partner of your success

Kinco Electric (Shenzhen) Ltd.

Address: 7/F, Bldg. 9th, Software Park, Keji Central Road 2nd, Nanshan District, Shenzhen, China (518057)

Tel: 86-755-2658555

Fax: 86-755-26616372

<http://www.kinco.cn>

Email: sales@kinco.cn